

MPR-722-PA
MPR-722R-PA



MPR-722R-PA

Pharmaceutical Refrigerator

High Performance Cooling
with EPA SNAP Compliant Refrigerants

24.2 cu.ft. | 684 L

23.7 cu.ft. | 671 L

The MPR-722-PA (shelves) and MPR-722R-PA (drawers) pharmaceutical refrigerators deliver a stable, reliable temperature control for clinical, pharmaceutical, biomedical storage and processing. Fast recovery following door openings assures safe storage during times of frequent access and high ambient conditions and to remove heat loads generated by powered instruments.

Positive Airflow Assures Quick Recovery, Interior Uniformity

Vertical, forced air circulation with dual blower creates a uniform temperature at all shelf or drawer levels, top to bottom and front to back. Internal shelf or drawer clearances permit the positive airflow also restores temperature to setpoint following door openings, and safely accommodates busy, high traffic demand for access to stored contents in pharmacies, clinics and hospitals.



Positive Airflow Prevents Temperature Stratification

The top-mounted air circulation blower creates a circular airflow within the chamber to provide uniform temperatures at all shelf levels to enhance and protect viability of stored product. Regardless of location, all products are subjected to the same safe temperature to assure repeatability of stored product viability.

Precision Temperature Control Protects Inventory

Because many pharmaceuticals are degraded or destroyed if accidentally frozen, it is important that temperature be adjusted to desired setpoint in accordance with drug manufacturers' insert specifications. MPR Series pharmaceutical refrigerators operate over a temperature range of 2°C to 23°C, adjustable in 1.0°C increments. Actual interior air temperature is displayed to 0.1°C.



Microprocessor Controls Simplify Operation

A microprocessor controller monitors all functions. Setpoint is factory set at 5°C. A soft key interface allows setpoint adjustment throughout the operating range. Audible and visual warnings indicate a door ajar or temperature deviation from setpoint. The large easy-to-read LED display confirms actual temperature.

Choose Your Inventory Management Preference

The MPR Series pharmaceutical refrigerator offers two choices in inventory management. The MPR-722-PA includes 4 open-wire shelves strong enough to hold bulk loads. The MPR-722R-PA is equipped with heavy-duty, fully-extendable painted steel pull-out drawers for more convenient access to stored product such as large bottles or reagent kits.

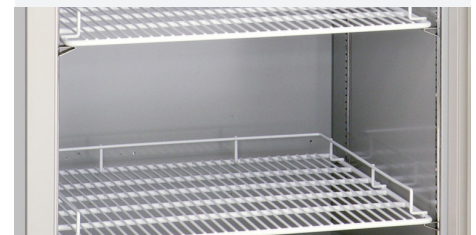

Adjustable Shelves Offer Flexibility in Storage Options

Open wire shelves (shown) are adjustable to allow for loads of varying heights such as bulk storage or process equipment such as fraction collectors. The Model MPR-722R-PA with pull-out drawers (not shown) offers a practical solution with additional ergonomic advantages.

Upright Pharmaceutical Refrigerator

MPR-722-PA | MPR-722R-PA



Model MPR-722-PA

Ideal for Storage or Process Instrumentation

The MPR-722-PA Series pharmaceutical refrigerator is configured to provide close temperature control for both storage and process applications where heat is generated from instrumentation or apparatus. A powerful refrigeration system using high performance compressors and components delivers fast temperature pull-down, recovery and tolerance for high ambient temperature conditions. Energy efficiency helps improve LEED scores and contribute to global sustainability.

Cycle Defrost Function

The cycle defrost and evaporator temperature sensor system ensures that defrost occurs only when necessary and automatically, so there is no need to turn off the power for defrosting. Irregular temperature increase during defrost is minimal with no temperature spikes. The evaporation heater also doubles as protection against drops in cabinet temperature caused by a low ambient temperature.

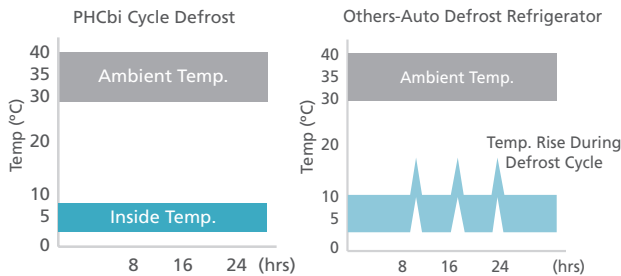

Dimensions

Unit : inch | mm

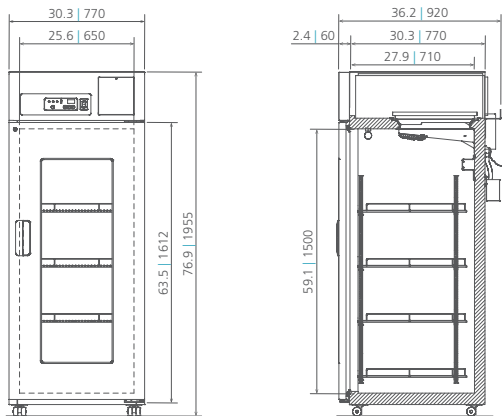

Model Number		MPR-722-PA	MPR-722R-PA
External Dimensions (W x D x H) ¹⁾	inches mm	30.3 x 36.2 x 76.9 770 x 920 x 1955	
Internal Dimensions (W x D x H)	inches mm	25.6 x 27.9 x 59.1 650 x 710 x 1500	
Volume	cu.ft. liters	24.2 684	23.7 671
Net Weight	lbs kg	334 174	425 193
Performance			
Power Consumption	watts	400	
Warranty ²⁾		1 year parts and labor, 3 years compressor	
Vaccine Storage Operating Temperature	°C	+2 to +8	
Factory Pre-Set Temperature	°C	+5	
Highest Ambient Temperature and Maintains Cabinet Temperature	°C	+2 to +23 (Ambient temperature 0 to +35, no load)	
Evaporator Prevents Vaccines from Freezing	°C	Operates above freezing at all times	
Temperature Control Range	°C	+2 to +23	
Control			
Microprocessor Controller, Adjustable	°C	Increments of 1.0	
Digital Temperature Display	°C	LED (displayed by 1, 0.1)	
Controller Security		Lockable with key pad	
Electronics Diagnostics		Total control system	
Refrigeration			
Cooling Method		Uniformity forced air	
Internal Airflow for Precise Temperature		Electronically monitored evaporator	
Defrost Method Initiated Only as Needed		Air cooled, CFC free	
Refrigeration System		CFC free urethane	
Insulation			
Construction			
Outer Door	qty	1 (dual pane glass)	
Interior		Zinc galvanized steel, Acrylic finish	
Exterior		Zinc galvanized steel, Acrylic finish	
Outer Door Lock		Key	
Interior Light		Yes - with control panel switch	
Shelves	qty	4 (adjustable, wire)	—
Drawers	qty	—	5 (solid)
Casters	qty	4 (2 swivel, 2 fixed)	
Access Port	qty	3 (left, right, top)	
Access Port Diameter	inches mm	1.1 30	
Alarms (V = Visual Alarm, B = Buzzer Alarm, R = Remote Alarm)			
Power Failure		R (V-B optional)	
Temperature (High and Low)		V-B-R	
Door Open		V-B	
Remote Alarm Contacts		Normally open, Normally closed, Common	
Remote Alarm Output		DC 24V 2A	
Electrical and Noise Level			
Power Supply		115V, 1Ø, 60Hz, NEMA 5-15P requires 5-15R receptacle	
Noise Level ³⁾	dB(A)	48	
Options			
Blackout Panels to Cover Glass	qty	1	
Optional Communication System			
Wireless, Cloud-Based, Automatic Data Management		LabAlert® Monitoring System	

¹⁾ Exterior dimensions of main cabinet only, excluding handle and other external projections. Consult product sales rep for doorway entry instructions, less than 36.2".

²⁾ Current warranty offered at time of printing and may be subject to change; US and Canada only

³⁾ Actual value, background noise 20 dB(A)

Specifications are subject to change without notice.

For latest specification information contact PHC Corporation of North America at info@phcd.com. Performance data herein is based on independent testing at time of publication.



PHC Corporation of North America
1300 Michael Drive, Suite A, Wood Dale, IL 60191
Toll Free USA (800) 858-8442, Fax (630) 238-0074
www.phcd.com/us/biomedical